

TPSK, TPSA, TPSAM

VANDAL RESISTANT ENCLOSURES



TPSK



TPSAM



TPSA

The TPSK surface mount enclosure has been engineered for optimum vandal resistance. The TPSA and TPSAM corner mount enclosures have been also been engineered for optimum vandal resistance. They are constructed of heavy steel and a Lexan® window to provide resistance against battery. Each TPSK has a uniquely keyed lock allowing access to only permitted security personnel.

The TPSK, TPSA and TPSAM are suitable for parking structures, police stations, correctional facilities, elevators, high security corridors or wherever a vandal resistant enclosure is required to secure a camera.

This enclosure opens like a clam shell and has adjustable camera bracket making installation easy.

- Constructed of 3mm heavy steel
- Vandal resistant Lexan® window
- Epoxy powder finish
- Each TPSA unit has a unique key lock
- Adjustable camera bracket
- 2-year limited warranty



TPSK, TPSA, TPSAM

TECHNICAL SPECIFICATIONS

MODELS

UL-TPSK	High-security, surface mount enclosure, steel, lexan window, Unique key lock , max. camera/lens size 5.0"W x 3.7"H x 12.0"L
UL-TPSKLL	High-security, surface mount enclosure, steel, lexan window, LIKE key locks , max. camera/lens size 5.0"W x 3.7"H x 12.0"L (call for lead time)
UL-TPSA	High-security, corner mount enclosure, steel, lexan window, Unique key lock , max. camera/lens size 5.0"W x 3.5"H x 9.0"L
UL-TPSALL	High-security, corner mount enclosure, steel, lexan window, LIKE key lock , max. camera/lens size 5.0"W x 3.5"H x 9.0"L (call for lead time)
UL-TPSAM	Medium-security, mini corner mount enclosure, steel, lexan window, max. camera/lens size 2.0"W x 2.0"H x 5.0"L
UL-SERTPSK	Key and lock replacement for TPSK (unique key)

MECHANICAL - TPSK

Camera Mounting	Slotted, adjustable camera sled
Maximum Camera Size	Accommodates camera/lens combinations (including BNC connector) up to: 5.0W x 3.7H x 12L in (127W x 94H x 305L mm)
Viewing Area	5.1W x 3.7H in. 130W x 94H mm
Viewing Window	Optically clear Lexan window
Cable Entry	Two compression fittings
Construction	3mm thick steel
Dimensions	7W x 6.8H x 15.4L in. (178W x 171H x 390L mm)
Weight	14.2 lbs (6.5kg)

GENERAL

Finish	Almond color, epoxy powder coating
Environment	Indoor

MECHANICAL - TPSA, TPSAM

Camera Mounting	Slotted, adjustable camera sled
Maximum Camera Size	Accommodates camera/lens combinations (including BNC connector) up to: TPSA 5.0W x 3.5H x 9.0L in. TPSAM 2.0W x 2.0H x 5.0L in.
Viewing Area:	
TPSA	3.25W/4.25W x 2.75H in.
TPSAM	1.8W/2.5W x 2.0H in.
Viewing Window	Optically clear Lexan® window
Cable Entry	Access on bottom sides
Construction	3mm thick steel
Dimensions	See drawings
Weight:	
TPSA	8.5 lbs (3.9kg)
TPSAM	2.7 lbs (1.2kg)

GENERAL

Finish	Almond color, epoxy powder coating
Environment	Indoor

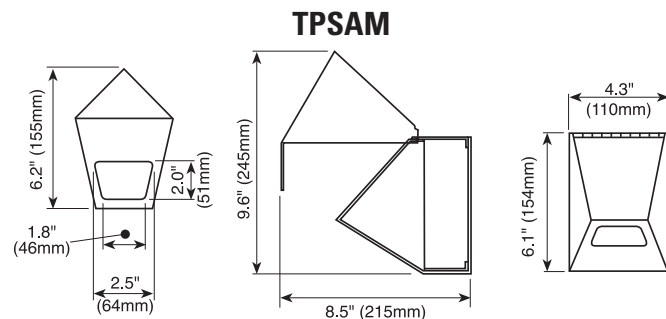
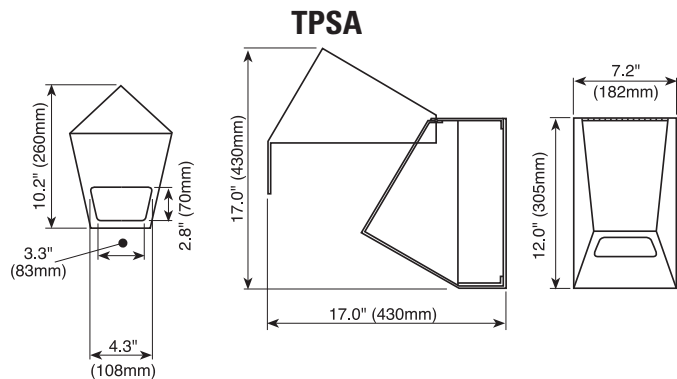
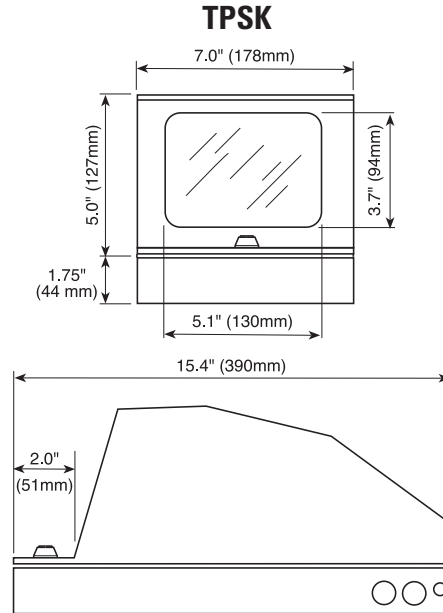

Design and specifications subject to change without notice.

Conversion: 1" = 25.4mm
Measurement conversions are approximate

Ultrak Worldwide Support Center:

1305 Waters Ridge Drive
Lewisville, TX 75057
(800) 796-2288 (972) 353-6500
Fax (972) 353-6670

